

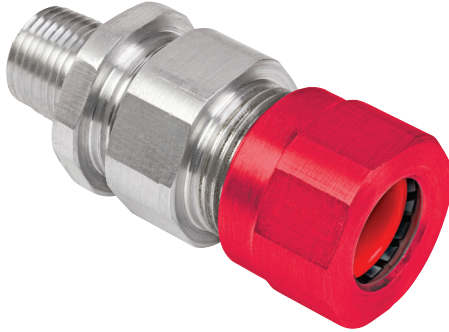

KILLARK®

INSTALLATION, OPERATION & MAINTENANCE DATA SHEET

MCX SERIES 45° & 90° CABLE GLANDS FOR USE WITH TYPE MC, MC-HL, TECK90-HL, RA90, RA90-HL, AC90, AC90-HL, ACWU90, and ACWU90HL CABLE



MCX SERIES 45° & 90° CABLE GLANDS FOR USE WITH TYPE MC, MC-HL, TECK90-HL, RA90, RA90-HL, AC90, AC90-HL, ACWU90, and ACWU90HL CABLE

CAUTION:

Before installing, make sure you are compliant with area classifications, failure to do so may result in bodily injury, death and property damage. Do not attempt installation until you are familiar with the following procedures. All installation must comply with the applicable Electrical Code.

Make sure that the circuit is de-energized before starting installation or maintenance.

Verify that the installation is grounded. Failure to ground will create electrical shock hazards, which can cause serious injury or death.

IMPORTANT:

Please read these instructions carefully before installing or maintaining this equipment. Good electrical practices should be followed at all times and this data should be used as a guide only.

Technical information, advice and recommendations contained in these documents is based upon information that Killark believes to be reliable. All the information and advice contained in these documents is intended for use only by persons having been trained and possessing the requisite skill and know-how and to be used by such persons only at their own discretion and risk. The nature of these instructions is informative only and does not cover all of the details, variations or combinations in which this equipment may be used, its storage, delivery, installation, check out, safe operation and maintenance. Since conditions of use of the product are outside of the care, custody and control of Killark, the purchaser should determine the suitability of the product for his intended use, and assumes all risk and liability whatsoever in connection therewith.



3940 Dr. Martin Luther King Drive
St. Louis, MO 63113

KIL00921464 FORM NO. K1464 06/15 ERO-8-029-15

Page 1 of 5

For Class I, Division 1, Groups A, B, C & D
 Class II, Division 1, Groups E, F & G; Class III.
 Type 3 and 4. IP66. Operating Temperature Range
 -50°C +60°C

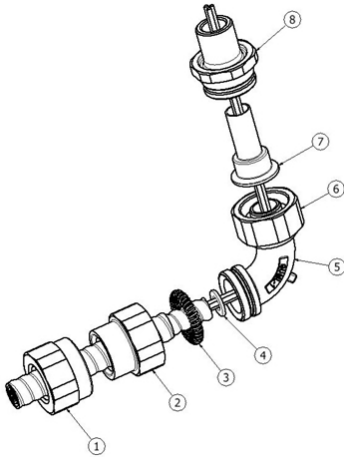

1. Back Nut
2. Middle Nut
3. Grounding Spring (Captive in the Middle Nut)
4. Armor Stop
5. Elbow
6. Locking Collar
7. Potting Chamber
8. Entry Component

1. ASSEMBLY INSTRUCTIONS

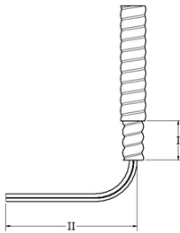

Figure A

STEP A (Refer to Figure A on left)

Strip cable to suit equipment as shown above, exposing metal armor sheath (I) and insulated cores (II).

I = 3/4" (19mm) for 1/2" size glands

I = 13/16" (21mm) for 3/4" size glands

I = 1" (25mm) for 1" size glands

I = 1-1/4" (32mm) for 1-1/4" size glands

II to suit equipment

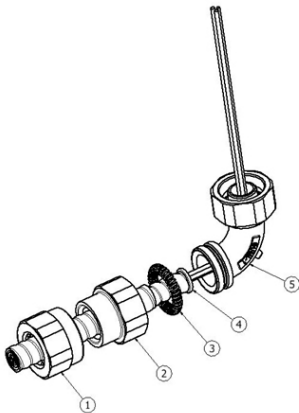

Figure B

STEP B (Refer to Figure B on left)

Push the cable through the back nut (1), middle nut (2), and grounding spring (3). Locate the armor stop (4) at the end of the armor as shown on left. If the conductors are too large to fit through the armor stop (4) it can be removed from the assembly. The elbow component (5) has a built in armor stop for larger cables. Feed the wires through the elbow and tighten the middle nut (2) and backnut (1) to the torque shown in Table A (Approximately hand tight + 1 turn). This will compress the grounding spring (3) to grip the armor for grounding.

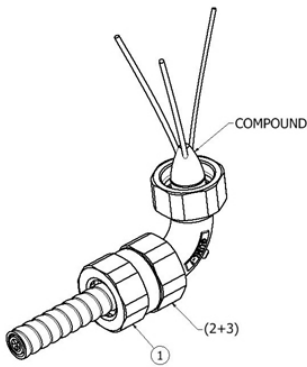

Figure C

STEP C (Refer to Figure C on left)

Spread out the cable cores and the individual strands of un-insulated conductors for the packing of the compound. Pack the compound between the cores and strands as shown on left. See Page 4 for compound preparation details.

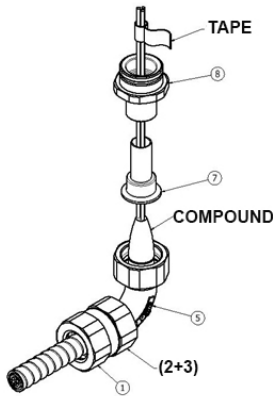

Figure D

STEP D (Refer to Figure D on left)

With all gaps and voids filled, bring the conductors back together and pack more compound around the outside of the conductors. Tape the conductors together to prevent disturbance of the compound. Press the potting chamber (7) over compound until it hits the elbow (5) see Figure E. Do not twist the potting chamber while pressing it over the compound. Twisting may create voids in the seal. For leverage the entry component (8) can be slid over the potting chamber starting with the NPT side. See Figure D.

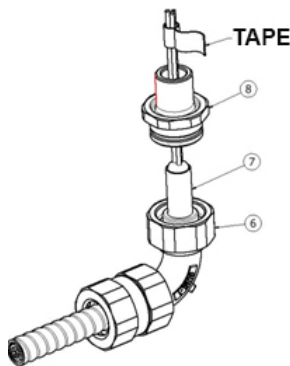

Figure E

STEP E (Refer to Figure E on left)

Install the entry component (8) over the potting chamber (7). Once the threads are started hold the entry component (8) stable and continue to tighten with the locking collar (6) to fully compress the potting chamber against the elbow to prevent the potting chamber (7) from rotating. See Figure E for after the potting has been fully compressed against the elbow.

STEP F (Refer to Figure F on left)

IMPORTANT NOTE:

The conductors must not be moved for a minimum of four hours. Take care during steps D and E to ensure that the conductors do not move.

If the gland is to be installed in a threaded opening first thread the entry component (8) into the enclosure to prevent twisting of the cable. When installing the entry component (8) into a NPT entry the component should be installed hand tight and then one additional turn with a wrench.

If the entry component (8) is installed with a locknut it should tighten to the torque shown in Table A. (Approximately hand tight +1 turn).

Slide the potting chamber (7) into the entry component (8). Take care to prevent compound from adhering to the inside of the entry component (8). Thread the locking collar (6) onto the entry component (8) to the torque show in Table A.

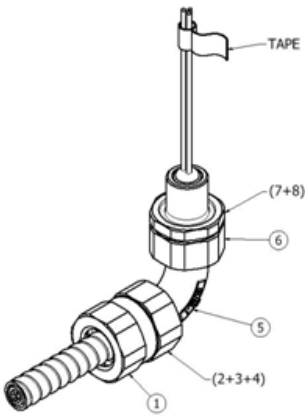
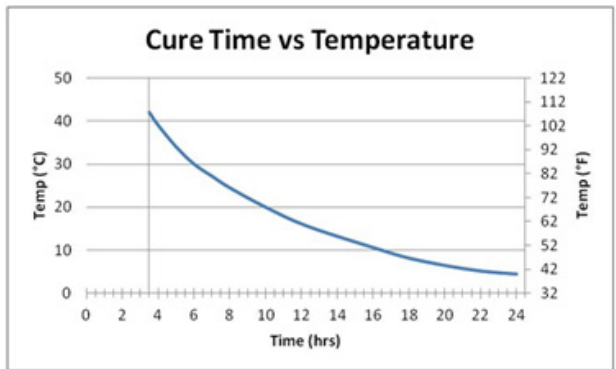

Figure F

Gland Size	Assembly Torque (lbf-ft)
1/2"	20
3/4"	20

2. EPOXY COMPOUND PREPARATION

1. The gloves provided must be worn when handling the epoxy.
2. The epoxy compound is supplied in a two part package. These parts are supplied in a ratio of 1:1 and should be mixed with this ratio until both colors have blended into one, without any streaks. Rolling and folding is the most effective method of obtaining an even blend.
3. Once mixed, the compound must be used within 30 minutes. After this time it will begin to stiffen. The compound should be kept at an ambient temperature of no less than 20°C (68°F) prior to using. At lower temperatures it becomes difficult to mix.
4. Once the compound is packed into the potting chamber it should be kept at an ambient temperature of at least 20°C (68°F) for 30 minutes to allow the curing process to start.
5. The compound must be allowed to fully cure prior to energizing the fitting. The minimum cure time is 3.5 hours and is dependent on the ambient temperature as shown by the graph below.
6. Should any compound come into contact with the skin it should be cleaned off with skin cleaner and not allowed to dry on the skin.



NOTES

1. Only compound for immediate use in terminations should be mixed.
2. The mixing and installation of the compound at an ambient temperature below 5°C (41°F) is not recommended due to extended curing periods.
3. The compound may be adversely affected by some solvent vapors. If such vapors are likely to be present in the vicinity of the cable gland in service, suitable precautions may be necessary. (Contact Hawke's Technical Dept).



3940 Dr. Martin Luther King Drive
St. Louis, MO 63113

KIL00921464 FORM NO. K1464 06/15 ERO-8-029-15

Page 5 of 5